

SAMSUNG

OPERATION TEST REPORT ON TDK CERAMIC RESONATOR

(FCR16.0M2G)

IC S3P848AXZZ(SAMSUNG)

AUG,05,2002

Sensors & Actuators Division,
TDK CORPORATION

ISSUED BY Chikako Tomizawa

APPROVED	CHECKED	CHECKED
I.Katoh		

1.Contents

(1) Oscillating circuit for evaluation	P.3
(2) Loading capacitance dependence of oscillating characteristics (CL1=CL2)	P.4
(3) Power supply voltage dependence of oscillating characteristics	P.5
(4) Temperature dependence of oscillating characteristics	P.6-7
(5) Open loop characteristics	P.8-9

2.Conclusions

We could confirm the operation satisfactory under
the following test conditions.

Test Conditions

IC	:	S3P848AXZZ (SAMSUNG)
Ceramic Resonator	:	FCR16.0M2G (Typical and worst sample are tested)
Power Supply Voltage	:	2.7(V) ~ 5.5(V)
Temperature Range	:	-25(°C) ~ 85(°C)
Loading capacitance(CL1=CL2)	:	10(pF)

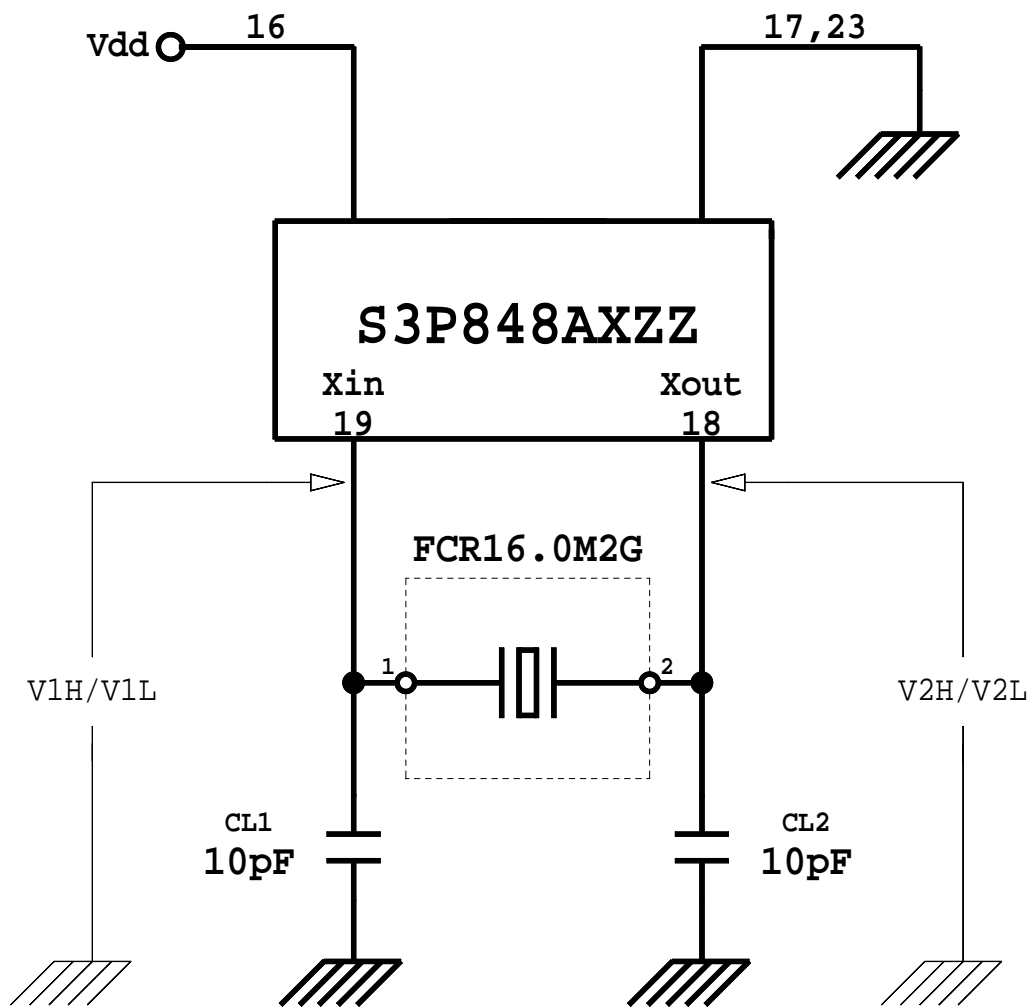

Oscillating circuit for evaluation

S3P848AXZZ - 1

FCR16.0M2G

V_{dd} = 5 [V] (Fig.a~d)

T_a = 20 [deg]

○—○ Typical

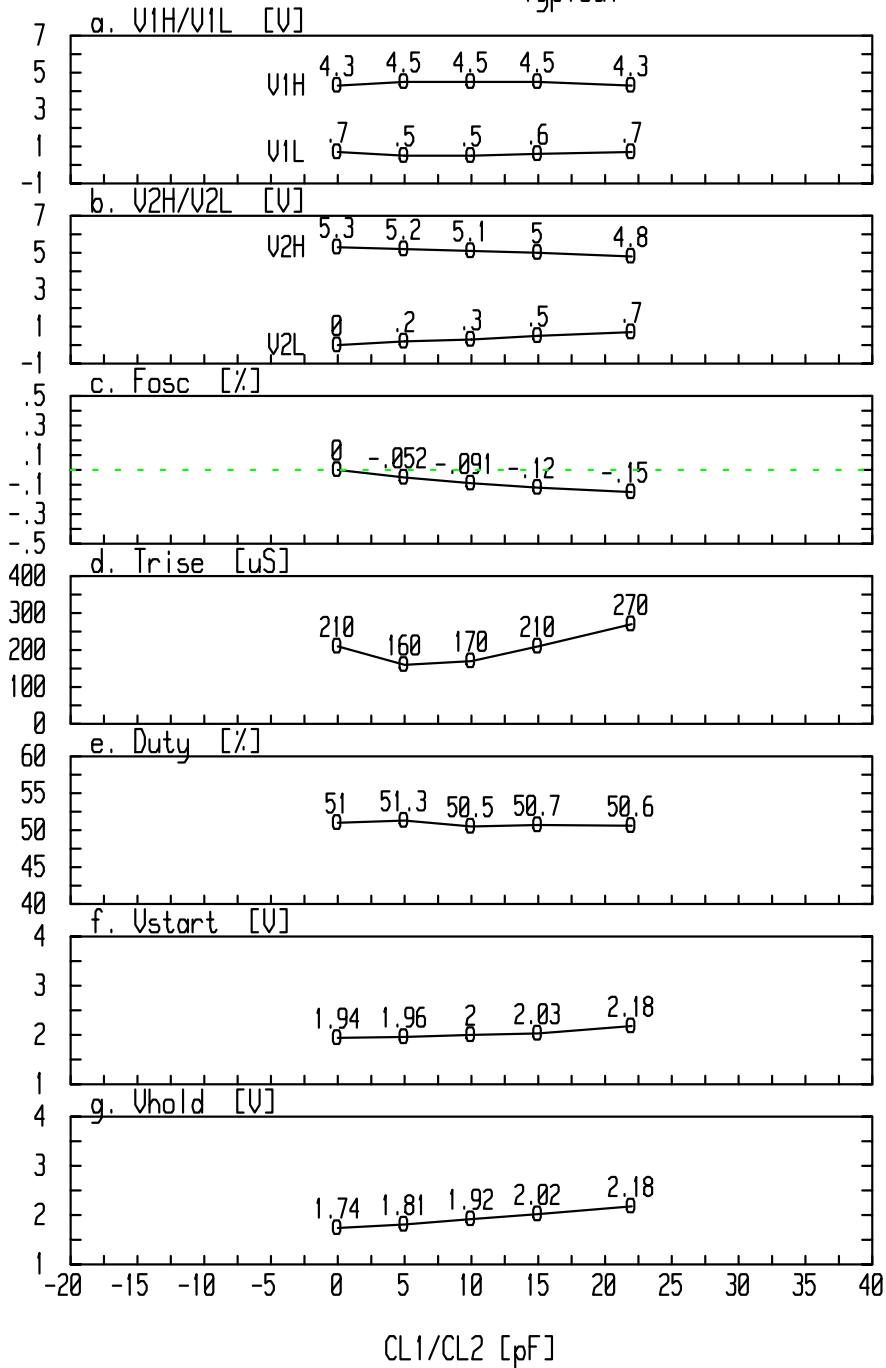

Loading capacitance dependence of oscillating characteristics (CL1=CL2)

S3P848AXZZ - 1
 CL1/CL2 [pF] 10 / 10

FCR16.0M2G
 Ta= 20 [deg]

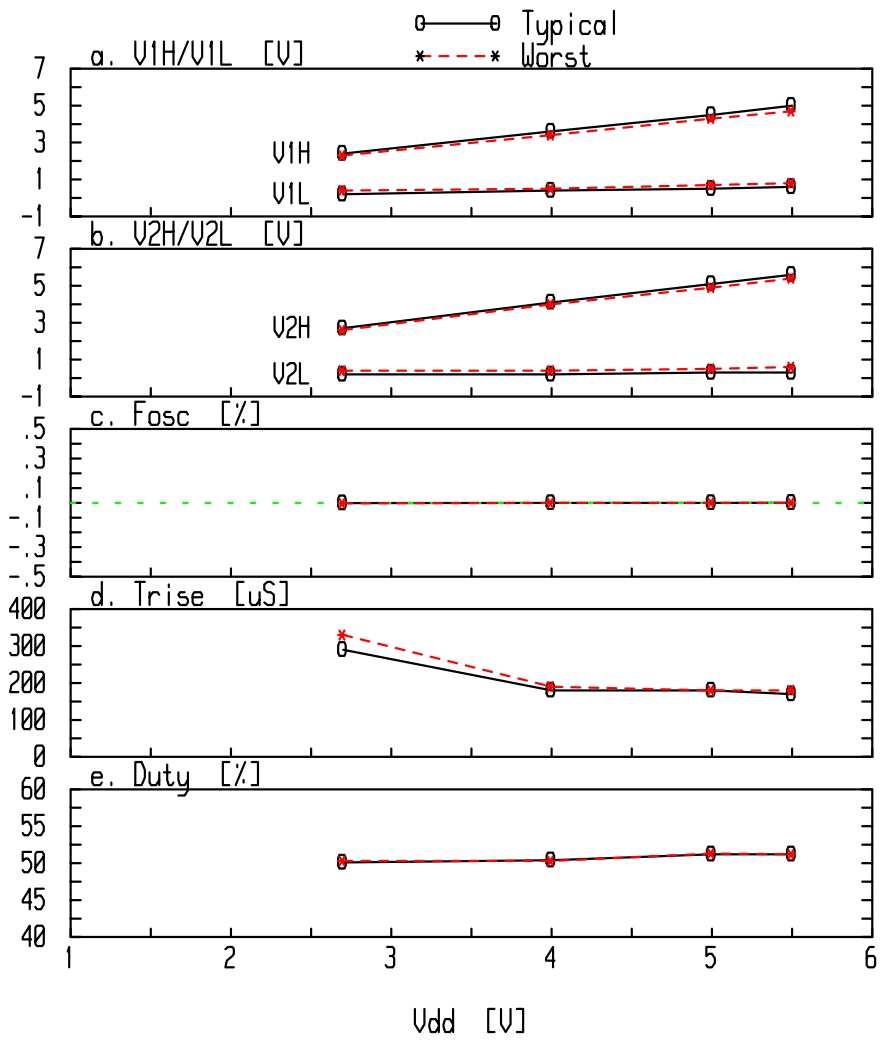

f. V_{start} [V]
 Typical = 2
 Worst = 2.08

g. V_{hold} [V]
 Typical = 1.92
 Worst = 2.07

Power supply voltage dependence of oscillating characteristics

S3P848AXZZ - 1
 CL1/CL2 [pF] 10 / 10

FCR16.0M2G
 Udd= 5 [V] (Fig.a~e)

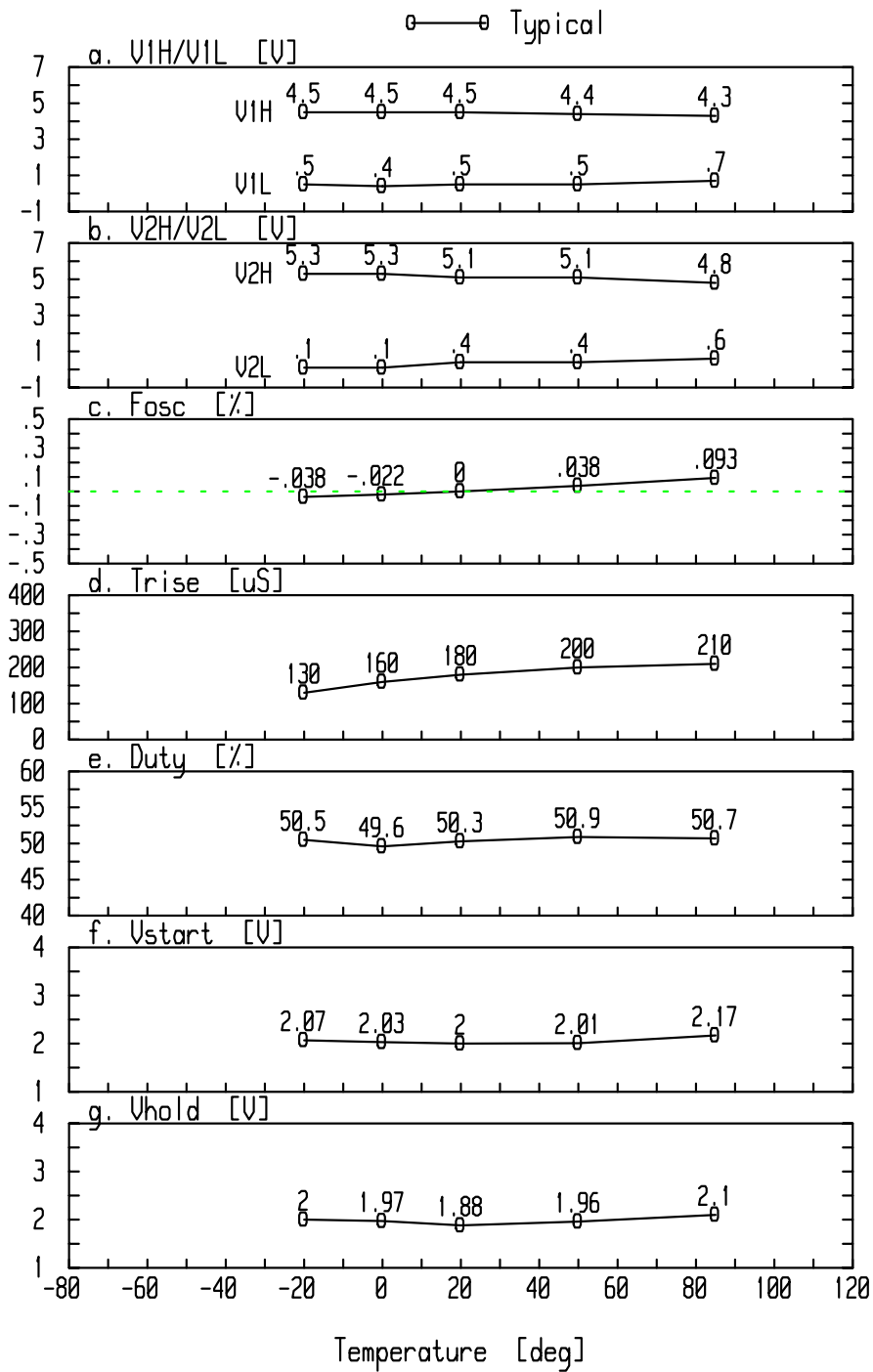

Temperature dependence of oscillating characteristics

S3P848AXZZ - 1
 CL1/CL2 [pF] 10 / 10

FCR16.0M2G
 U_{dd} = 5 [V] (Fig. a~e)

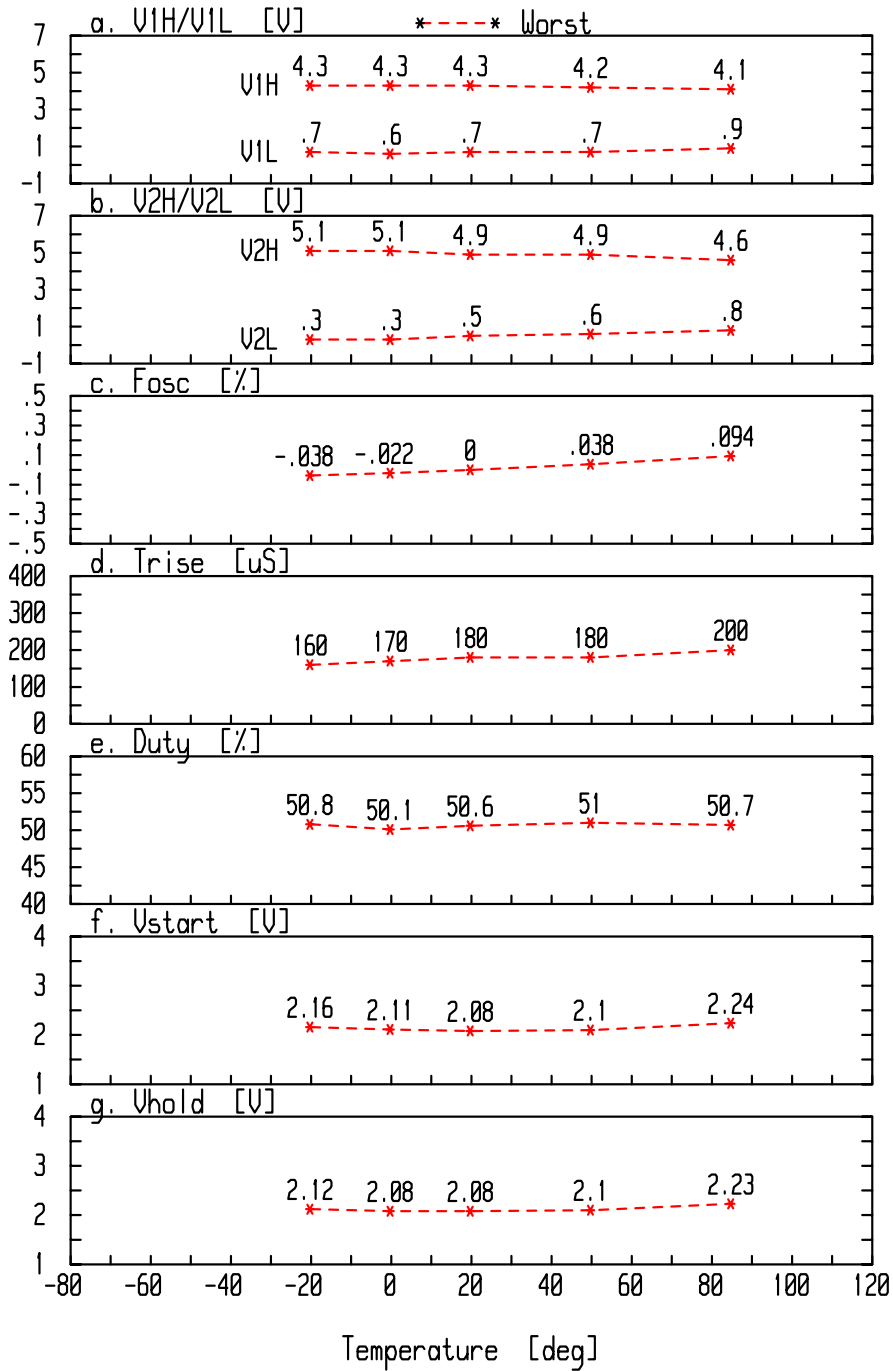

Temperature dependence of oscillating characteristics

S3P848AXZZ - 1
 FCR16.0M2G - Typical
 Vdd [V] 5
 CL1/CL2 [pF] 10 / 10

	[B]	[C]	[D]
Gmax [dB]	10.91	17.88	7.63
LGM [dB]	0	17.85	7.51
Pmin [deg]	6.56	-76.66	-64.08
LPM [deg]	6.56	-76.03	-55.38

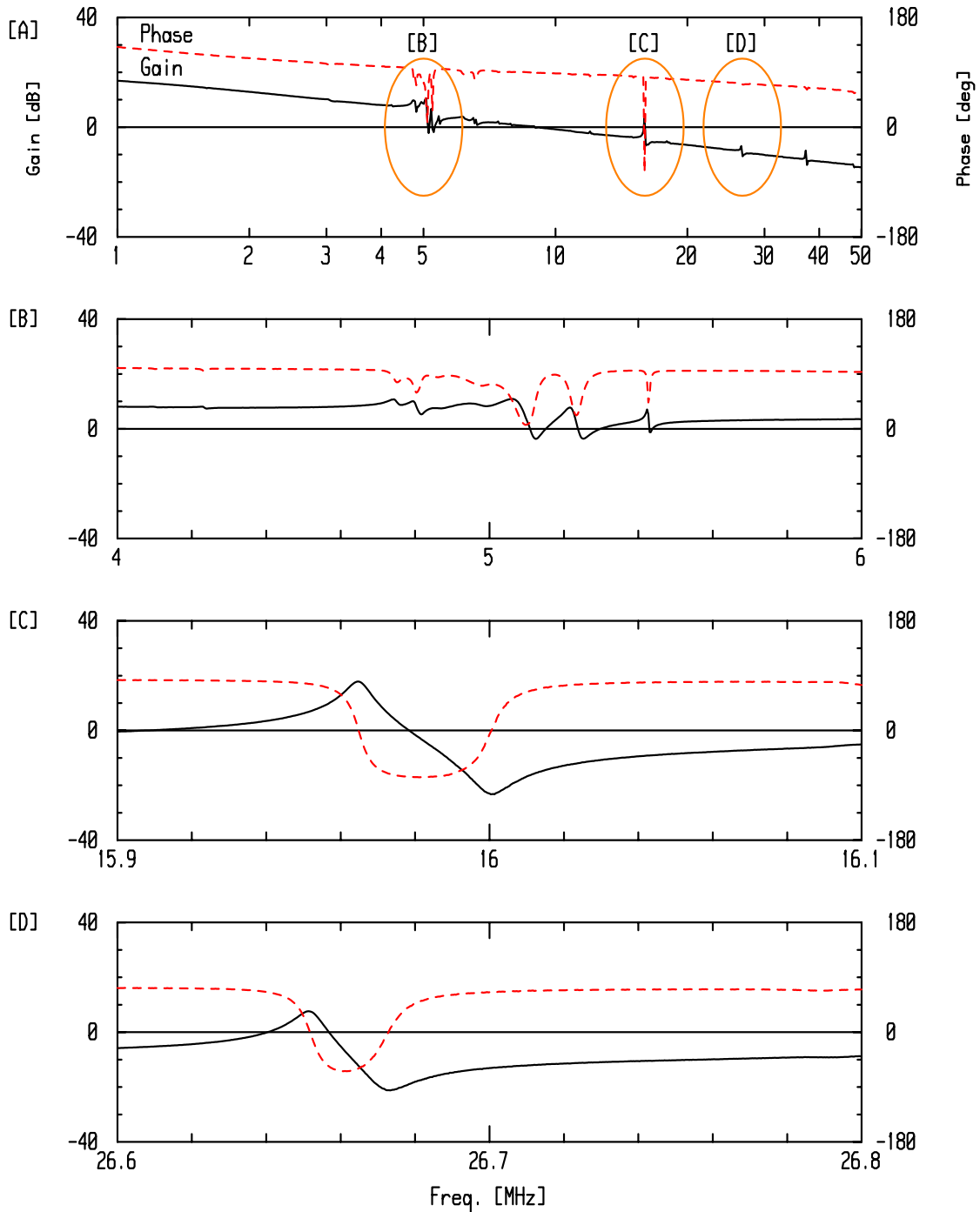

Open loop characteristics (Typical Sample)

S3P848AXZZ - 1
 FCR16.0M2G - Worst
 Vdd [V] 5
 CL1/CL2 [pF] 10 / 10

	[B]	[C]	[D]
Gmax [dB]	10.66	16.07	7.06
LGM [dB]	0	16.05	7.03
Pmin [deg]	19.22	-73.98	-62.21
LPM [deg]	19.22	-72.95	-53.36

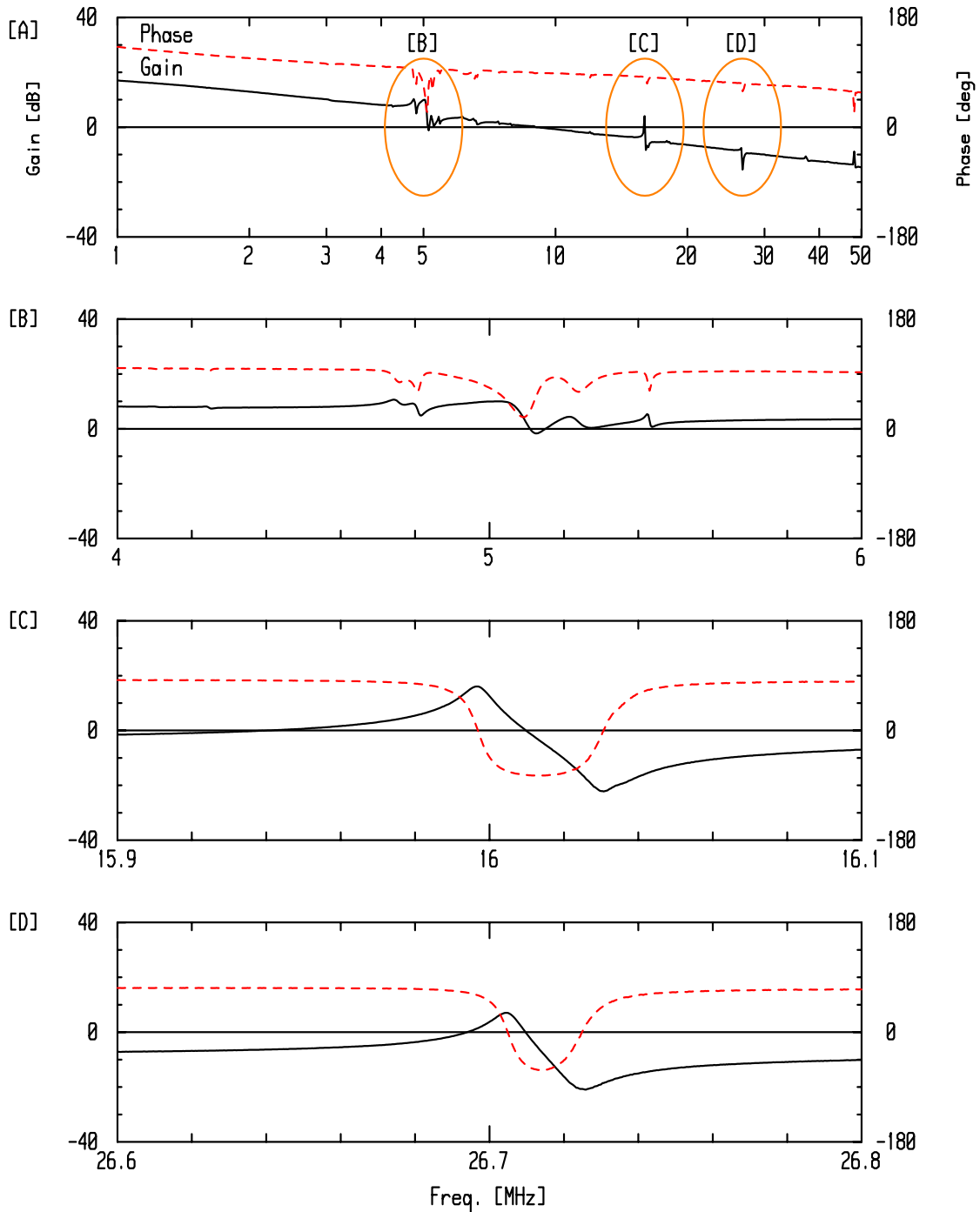

Open loop characteristics (Worst Sample)